

INTERNATIONAL STANDARD

**Conduit systems for cable management –
Part 22: Particular requirements – Pliable conduit systems**





THIS PUBLICATION IS COPYRIGHT PROTECTED
Copyright © 2021 IEC, Geneva, Switzerland

All rights reserved. Unless otherwise specified, no part of this publication may be reproduced or utilized in any form or by any means, electronic or mechanical, including photocopying and microfilm, without permission in writing from either IEC or IEC's member National Committee in the country of the requester. If you have any questions about IEC copyright or have an enquiry about obtaining additional rights to this publication, please contact the address below or your local IEC member National Committee for further information.

IEC Central Office
3, rue de Varembe
CH-1211 Geneva 20
Switzerland

Tel.: +41 22 919 02 11
info@iec.ch
www.iec.ch

About the IEC

The International Electrotechnical Commission (IEC) is the leading global organization that prepares and publishes International Standards for all electrical, electronic and related technologies.

About IEC publications

The technical content of IEC publications is kept under constant review by the IEC. Please make sure that you have the latest edition, a corrigendum or an amendment might have been published.

IEC publications search - webstore.iec.ch/advsearchform

The advanced search enables to find IEC publications by a variety of criteria (reference number, text, technical committee, ...). It also gives information on projects, replaced and withdrawn publications.

IEC Just Published - webstore.iec.ch/justpublished

Stay up to date on all new IEC publications. Just Published details all new publications released. Available online and once a month by email.

IEC Customer Service Centre - webstore.iec.ch/csc

If you wish to give us your feedback on this publication or need further assistance, please contact the Customer Service Centre: sales@iec.ch.

IEC online collection - oc.iec.ch

Discover our powerful search engine and read freely all the publications previews. With a subscription you will always have access to up to date content tailored to your needs.

Electropedia - www.electropedia.org

The world's leading online dictionary on electrotechnology, containing more than 22 000 terminological entries in English and French, with equivalent terms in 18 additional languages. Also known as the International Electrotechnical Vocabulary (IEV) online.



IEC 61386-22

Edition 2.0 2021-04

INTERNATIONAL STANDARD

**Conduit systems for cable management –
Part 22: Particular requirements – Pliable conduit systems**

INTERNATIONAL
ELECTROTECHNICAL
COMMISSION

ICS 29.120.10

ISBN 978-2-8322-9666-0

Warning! Make sure that you obtained this publication from an authorized distributor.

CONTENTS

FOREWORD	3
1 Scope	5
2 Normative references	5
3 Terms and definitions	5
4 General requirements	5
5 General conditions for tests	5
6 Classification	5
7 Marking and documentation	5
8 Dimensions	6
9 Construction	7
10 Mechanical properties	7
11 Electrical properties	9
12 Thermal properties	9
13 Fire hazard	9
14 External influences	9
15 Electromagnetic compatibility	9
Annex A (normative) Classification coding for conduit systems	13
Annex B (normative) Determination of material thickness	13
Annex C (normative) Additional test requirements for conduit systems already complying with IEC 61386-1:2008	13
Annex AA (informative) Calculation for minimum and maximum rate of increase of force for 10.2.4	14
Figure 101 – Bending test apparatus	10
Figure 102 – Gauge for checking the minimum inside diameter of the conduit system after impact, bending, and resistance to heat tests	11
Figure 103 – Assembly of conduit and terminating conduit fitting for bonding test	12
Figure AA.1 – Graph showing force against time for 750 N force	14
Table 101 – Thread lengths	6
Table 102 – Maximum entry diameter and minimum entry length details	7
Table AA.1 – Minimum and maximum rate of increase of force for 10.2.4	15

INTERNATIONAL ELECTROTECHNICAL COMMISSION

CONDUIT SYSTEMS FOR CABLE MANAGEMENT –**Part 22: Particular requirements – Pliable conduit systems****FOREWORD**

- 1) The International Electrotechnical Commission (IEC) is a worldwide organization for standardization comprising all national electrotechnical committees (IEC National Committees). The object of IEC is to promote international co-operation on all questions concerning standardization in the electrical and electronic fields. To this end and in addition to other activities, IEC publishes International Standards, Technical Specifications, Technical Reports, Publicly Available Specifications (PAS) and Guides (hereafter referred to as “IEC Publication(s)”). Their preparation is entrusted to technical committees; any IEC National Committee interested in the subject dealt with may participate in this preparatory work. International, governmental and non-governmental organizations liaising with the IEC also participate in this preparation. IEC collaborates closely with the International Organization for Standardization (ISO) in accordance with conditions determined by agreement between the two organizations.
- 2) The formal decisions or agreements of IEC on technical matters express, as nearly as possible, an international consensus of opinion on the relevant subjects since each technical committee has representation from all interested IEC National Committees.
- 3) IEC Publications have the form of recommendations for international use and are accepted by IEC National Committees in that sense. While all reasonable efforts are made to ensure that the technical content of IEC Publications is accurate, IEC cannot be held responsible for the way in which they are used or for any misinterpretation by any end user.
- 4) In order to promote international uniformity, IEC National Committees undertake to apply IEC Publications transparently to the maximum extent possible in their national and regional publications. Any divergence between any IEC Publication and the corresponding national or regional publication shall be clearly indicated in the latter.
- 5) IEC itself does not provide any attestation of conformity. Independent certification bodies provide conformity assessment services and, in some areas, access to IEC marks of conformity. IEC is not responsible for any services carried out by independent certification bodies.
- 6) All users should ensure that they have the latest edition of this publication.
- 7) No liability shall attach to IEC or its directors, employees, servants or agents including individual experts and members of its technical committees and IEC National Committees for any personal injury, property damage or other damage of any nature whatsoever, whether direct or indirect, or for costs (including legal fees) and expenses arising out of the publication, use of, or reliance upon, this IEC Publication or any other IEC Publications.
- 8) Attention is drawn to the Normative references cited in this publication. Use of the referenced publications is indispensable for the correct application of this publication.
- 9) Attention is drawn to the possibility that some of the elements of this IEC Publication may be the subject of patent rights. IEC shall not be held responsible for identifying any or all such patent rights.

International Standard IEC 61386-22 has been prepared by subcommittee 23A: Cable management systems, of IEC technical committee 23: Electrical accessories:

This second edition cancels and replaces the first edition published in 2002. This edition constitutes a technical revision.

This edition includes the following significant technical changes with respect to the previous edition:

- a) Annex AA has been added to provide guidance on the application of a constantly increasing force.

The text of this International Standard is based on the following documents:

FDIS	Report on voting
23A/951/FDIS	23A/956/RVD

Full information on the voting for the approval of this International Standard can be found in the report on voting indicated in the above table.

This document has been drafted in accordance with the ISO/IEC Directives, Part 2.

A list of all the parts in the IEC 61386 series, published under the general title *Conduit systems for cable management*, can be found on the IEC website.

This document is to be used in conjunction with IEC 61386-1:2008 and IEC 61386-1:2008/AMD1:2017.

This document supplements or modifies the corresponding clauses of IEC 61386-1:2008 and IEC 61386-1:2008/AMD1:2017. Where a particular clause or subclause of IEC 61386-1:2008 and IEC 61386-1:2008/AMD1:2017 is not mentioned in this document, that clause or subclause applies as far as is reasonable. Where this document states "addition", "modification" or "replacement", the relevant text of IEC 61386-1:2008 and IEC 61386-1:2008/AMD1:2017 is to be adapted accordingly.

Subclauses, tables and figures which are in addition to those in IEC 61386-1:2008 and IEC 61386-1:2008/AMD1:2017 are numbered starting with 101. Annexes which are additional to those in IEC 61386-1:2008 and IEC 61386-1:2008/AMD1:2017 are lettered AA, BB, etc.

In this document, the following print types are used:

- Requirements proper: in roman type.
- *Test specifications: in italic type.*
- Explanatory matter: in smaller roman type.

The committee has decided that the contents of this document will remain unchanged until the stability date indicated on the IEC website under "<http://webstore.iec.ch>" in the data related to the specific document. At this date, the document will be

- reconfirmed,
- withdrawn,
- replaced by a revised edition, or
- amended.

CONDUIT SYSTEMS FOR CABLE MANAGEMENT –

Part 22: Particular requirements – Pliable conduit systems

1 Scope

Clause 1 of IEC 61386-1:2008 is applicable, except as follows:

Addition:

This part of IEC 61386 specifies the requirements for pliable conduit systems including self-recovering conduit systems.

2 Normative references

Clause 2 of IEC 61386-1:2008 and of IEC 61386-1:2008/AMD1:2017 are applicable, except as follows:

Addition:

IEC 61386-1:2008, *Conduit systems for cable management – Part 1: General requirements*
IEC 61386-1:2008/AMD1:2017

3 Terms and definitions

Clause 3 of IEC 61386-1:2008 and of IEC 61386-1:2008/AMD1:2017 are applicable.

4 General requirements

Clause 4 of IEC 61386-1:2008 is applicable.

5 General conditions for tests

Clause 5 of IEC 61386-1:2008 and of IEC 61386-1:2008/AMD1:2017 are applicable.

6 Classification

Clause 6 of IEC 61386-1:2008 is applicable, except as follows:

Classifications 6.1.1, 1; 6.1.2, 1; 6.1.3, 1; 6.1.3, 4; 6.1.4, 1 and 6.1.5, 1 are not applicable.

NOTE Pliable conduit systems according to 6.1.1, 2 and 6.1.2, 2 and classification 1 from 6.2.1, Table 1 are not allowed in France.

7 Marking and documentation

Clause 7 of IEC 61386-1:2008 and of IEC 61386-1:2008/AMD1:2017 are applicable, except as follows:

Addition:

7.1.101 The conduit shall be marked in accordance with 7.1 along its entire length at regular intervals of preferably 1 m but not longer than 3 m. Where this is technically impractical, the mark shall be on a label attached to the product at each end or on the packaging.

Compliance is checked by inspection.

7.1.102 The manufacturer shall document, for the conduit system, the minimum inside diameter and the classification in accordance with Clause 6.

Compliance is checked by inspection of the manufacturer's documentation.

8 Dimensions

Replacement:

8.1 Threads shall comply with IEC 60423.

Outside diameters of non-metallic conduit shall comply with IEC 60423.

Outside diameters of metallic and composite conduits need not comply with IEC 60423, provided that they are designed to be installed only with terminating conduit fittings having threads complying with IEC 60423.

Compliance is checked by means of the gauges specified in IEC 60423.

8.2 Threadable conduits and threadable conduit fittings, except terminating conduit fittings, shall comply with Table 101. Non-threadable conduit fittings, except fittings which are part of a conduit system declaring tensile strength, shall comply with Table 102. The minimum inside diameter of the conduit system shall be as declared by the manufacturer.

Compliance is checked by measurement.

Table 101 – Thread lengths

Size	External thread	Internal thread
	Minimum length	Minimum length
mm	mm	mm
6	05,5	06,5
8	06,5	07,5
10	08,5	09,5
12	10,5	11,5
16	12,5	13,5
20	14,0	15,0
25	17,0	18,0
32	19,0	20,0
40	19,0	20,0
50	19,0	20,0
63	19,0	20,0
75	19,0	20,0

Table 102 – Maximum entry diameter and minimum entry length details

Size	Maximum entry diameter	Minimum entry length
mm	mm	mm
6	06,5	06,0
8	08,5	08,0
10	10,5	10,0
12	12,5	12,0
16	16,5	16,0
20	20,5	20,0
25	25,5	25,0
32	32,6	30,0
40	40,7	32,0
50	50,8	42,0
63	63,9	50,0
75	75,9	50,0

9 Construction

Clause 9 of IEC 61386-1:2008 is applicable.

10 Mechanical properties

Clause 10 of IEC 61386-1:2008 and of IEC 61386-1:2008/AMD1:2017 are applicable, except as follows:

10.2 Compression test

Subclause 10.2 is applicable with the following addition:

10.2.4 Add the following note at the end of Subclause 10.2.4:

NOTE In order to achieve a uniformly increasing compression force, the force indicated in Table 4 is divided by time; this value is the required rate per second to fulfil the requirement.

Example: For a test force of 750 N an increase of the test force of 25 N/s is required (750 divided by 30 equals 25). Informative Annex AA gives detailed calculations including tolerances for time and force.

For self-recovering conduits, replace Subclauses 10.2.4, 10.2.5, 10.2.6, 10.2.7 and 10.2.8, with the following:

10.2.101 The intermediate steel piece shall be subjected to a uniformly increasing compression force (N) reaching the force indicated in Table 4 after (30 ± 3) s. The sample shall flatten by between 25 % and 50 % of its initial outside diameter.

If the sample flattens by less than 25 %, an additional test is carried out whereby the intermediate steel piece is lowered onto the sample at constant speed until the sample is flattened by (30 ± 3) % after (30 ± 3) s and the resultant force is measured.

A new sample is subjected to the uniformly increasing force (N) reaching the force measured above after (30 ± 3) s. The sample shall flatten by between 25 % and 50 % of its initial outside diameter.

The force and the intermediate steel piece shall then be removed. Fifteen minutes after removal, the outside diameter of the sample, where it has flattened, shall be measured again.

After the test, the difference between the initial outside diameter and the outside diameter of the flattened sample shall not exceed 10 % of the outside diameter, as measured before the test, and the sample shall show no cracks visible to normal or corrected vision without magnification.

10.4 Bending test

Replacement:

10.4.101 Conduits shall be subjected to a bending test by means of the apparatus as shown in Figure 101.

10.4.102 The test shall be made on six samples of conduit, the length of each sample being at least:

- a) 30 times the nominal outside diameter for plain conduits;
- b) 12 times the nominal outside diameter for corrugated conduits.

Three of the samples shall be tested at ambient temperature; the other three shall be tested at the minimum declared temperature for transport, application and installation according to Table 1, with a tolerance of ± 2 °C.

10.4.103 For the test at ambient temperature, the sample shall be clamped vertically in the bending apparatus as shown in Figure 101. The sample shall be slowly bent by hand to the left through an angle of $(90 \pm 5)^\circ$, then back to the vertical position, then to the right through an angle of $(90 \pm 5)^\circ$, and then back to the vertical position. This sequence of operations shall be repeated three more times but at the end the sample shall not be bent back to the vertical position. The sample shall be maintained in the bent position for 5 min, after which it shall be placed in such a position that the straight portions are at an angle of $(45 \pm 5)^\circ$ to the vertical, one end of the sample pointing upwards and the other downwards.

For the test at the minimum declared temperature for transport, application and installation according to Table 1, the sample clamped in the bending apparatus as shown in Figure 101 shall be conditioned before the test for 2 h in a cold chamber at the aforementioned minimum declared temperature with a tolerance of ± 2 °C.

After the test, the sample shall show no cracks visible to normal or corrected vision without magnification and it shall be possible to pass the appropriate gauge, as shown in Figure 102, through the sample under its own weight and without any initial speed.

10.5 Flexing test

Subclause 10.5 of IEC 61386-1:2008 is not applicable.

10.6 Collapse test

Subclause 10.6 of IEC 61386-1:2008 is not applicable.

10.7 Tensile test

Subclause 10.7 of IEC 61386-1:2008 is applicable, except as follows:

10.7.3 Not applicable.

11 Electrical properties

Clause 11 of IEC 61386-1:2008 and of IEC 61386-1:2008/AMD1:2017 are applicable, except as follows:

11.2 Bonding test

Replacement:

A sample of a conduit and terminating conduit fitting shall be assembled in accordance with the manufacturer's instructions and mounted as shown in Figure 103. A current of 25 A, having a frequency of 50 Hz to 60 Hz, derived from an AC source having a no-load voltage not exceeding 12 V, shall be passed through the assembly for 1 min ⁺⁵₀ s. Then the voltage drop shall be measured between the points as shown in Figure 103 and the resistance calculated from the current and this voltage drop.

The resistance shall not exceed 0,05 Ω.

12 Thermal properties

Clause 12 of IEC 61386-1:2008 is applicable, except as follows:

12.3 *Replacement:*

The load is then removed and immediately after its removal it shall be possible to pass the appropriate gauge, as shown in Figure 102, through the conduit under its own weight and without any initial speed, with the sample in the vertical position.

13 Fire hazard

Clause 13 of IEC 61386-1:2008 and of IEC 61386-1:2008/AMD1:2017 are applicable.

14 External influences

Clause 14 of IEC 61386-1:2008 and of IEC 61386-1:2008/AMD1:2017 are applicable.

15 Electromagnetic compatibility

Clause 15 of IEC 61386-1:2008 and of IEC 61386-1:2008/AMD1:2017 are applicable.

Addition:

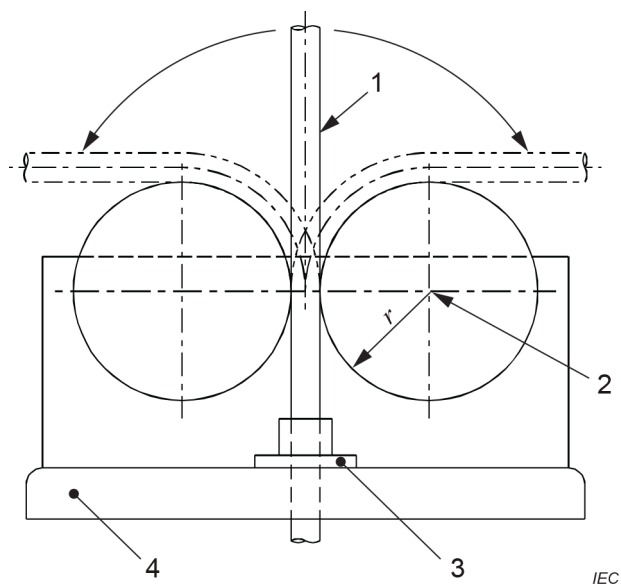

Key

- 1 Sample
- 2 Centre
- 3 Guide for conduit
- 4 Support

Size mm	Radius <i>r</i> mm	
	Plain conduits	Corrugated conduits
6	40	20
8	50	25
10	60	30
12	80	40
16	96	48
20	120	60
25	150	75
32	192	96
40	300	160
50	480	200
63	600	252
75	720	300

NOTE This drawing is not intended to govern design except as regards the dimensions shown.

Figure 101 – Bending test apparatus

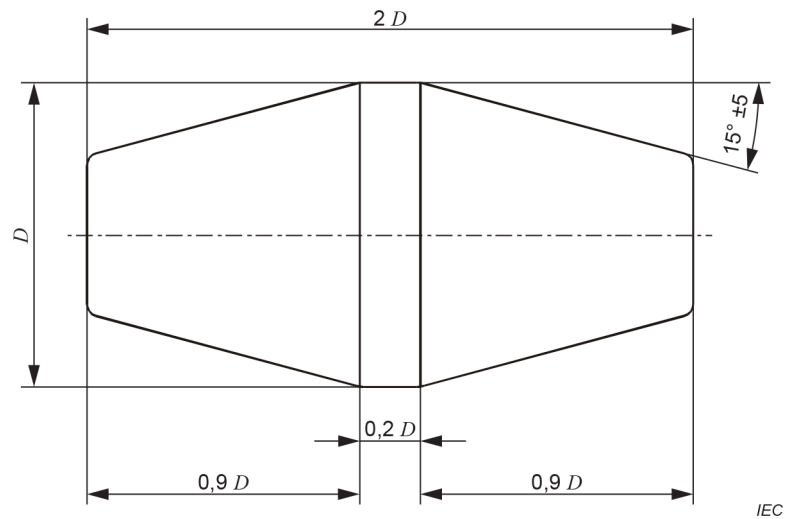

<i>D</i> :	80 % of the manufacturer's declared minimum inside diameter of the conduit system
Material:	Steel, hardened and polished, edges slightly rounded
Manufacturing tolerance:	$+0,05$ 0 mm
Tolerance and axial dimension:	$\pm 0,2$ mm
Admissible wear:	0,01 mm

NOTE The drawing is not intended to govern design except as regards the dimensions shown.

Figure 102 – Gauge for checking the minimum inside diameter of the conduit system after impact, bending, and resistance to heat tests

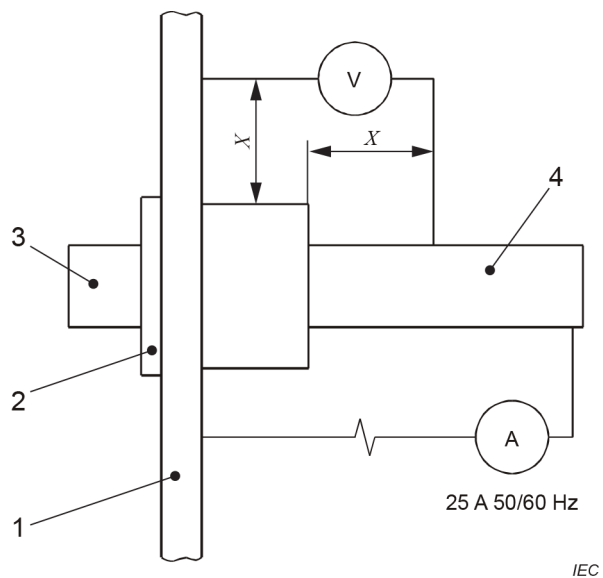

Key

$X = 12 \text{ mm} \pm 2 \text{ mm}$

1 3 mm steel plate

2 Optional locknut

3 Terminating conduit fitting secured to plate by tapped hole or by locknut on fitting thread

4 Conduit

Figure 103 – Assembly of conduit and terminating conduit fitting for bonding test

Annex A
(normative)

Classification coding for conduit systems

Annex A of IEC 61386-1:2008 is applicable.

Annex B
(normative)

Determination of material thickness

Annex B of IEC 61386-1:2008 is applicable.

Annex C
(normative)

**Additional test requirements for conduit systems already
complying with IEC 61386-1:2008**

Annex C of IEC 61386-1:2008 and of IEC 61386-1:2008/AMD1:2017 are applicable.

Addition:

Annex AA (informative)

Calculation for minimum and maximum rate of increase of force for 10.2.4

The following information is provided to assist test engineers to calculate the required rate of increase of force vs time for compression test machines which have tolerances on the rate of load application.

Calculations for minimum and maximum rate of increase of force for 10.2.4:

- minimum rate equals minimum force (Table 4) divided by maximum time (33 s);
- nominal rate equals nominal force (Table 4) divided by nominal time (30 s);
- maximum rate equals maximum force (Table 4 +4 %) divided by minimum time (27 s).

For 750 N force, this can be shown by Figure AA.1 as force (N) against time (s).

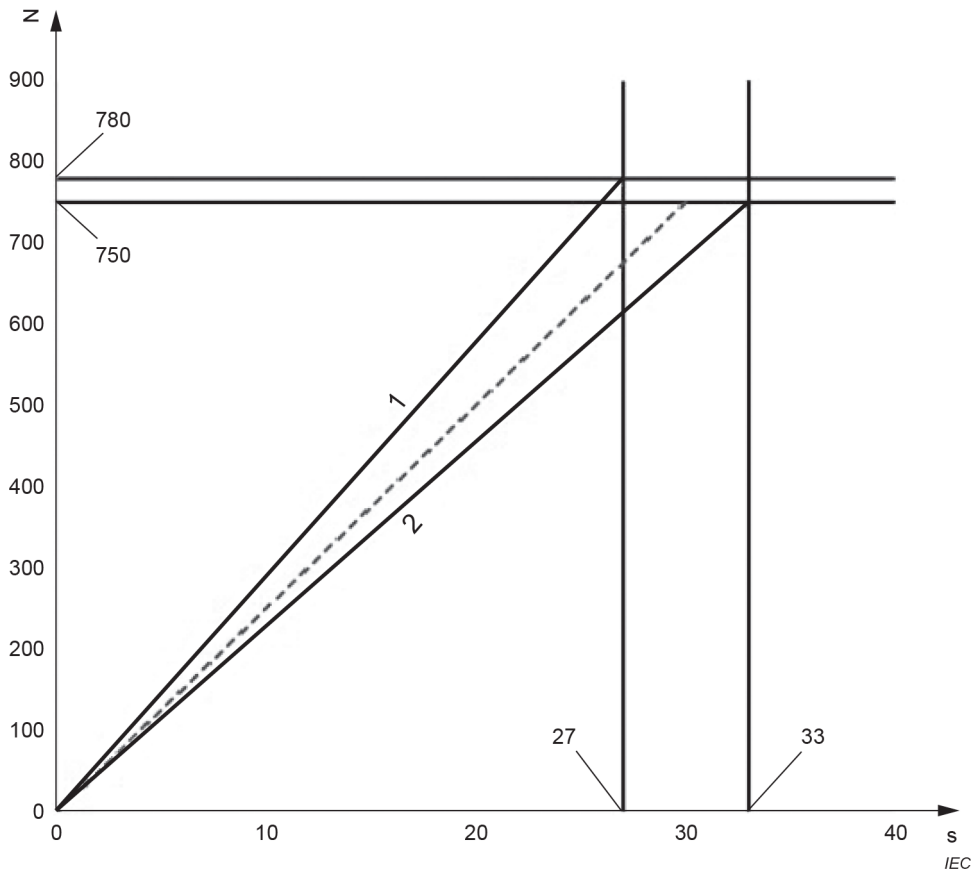

Key

Line 1. is maximum rate

Line 2. is minimum rate

Figure AA.1 – Graph showing force against time for 750 N force

For all force levels, the calculations are as given in Table AA.1.

Table AA.1 – Minimum and maximum rate of increase of force for 10.2.4

Compression force (N)	Rate (N/s)		
	Minimum	Nominal	Maximum
125	3,8	4,2	4,8
320	9,7	10,7	12,3
750	22,7	25,0	28,9
1 250	37,9	41,7	48,1
4 000	121,2	133,3	154,1

INTERNATIONAL
ELECTROTECHNICAL
COMMISSION

3, rue de Varembé
PO Box 131
CH-1211 Geneva 20
Switzerland

Tel: + 41 22 919 02 11
info@iec.ch
www.iec.ch